

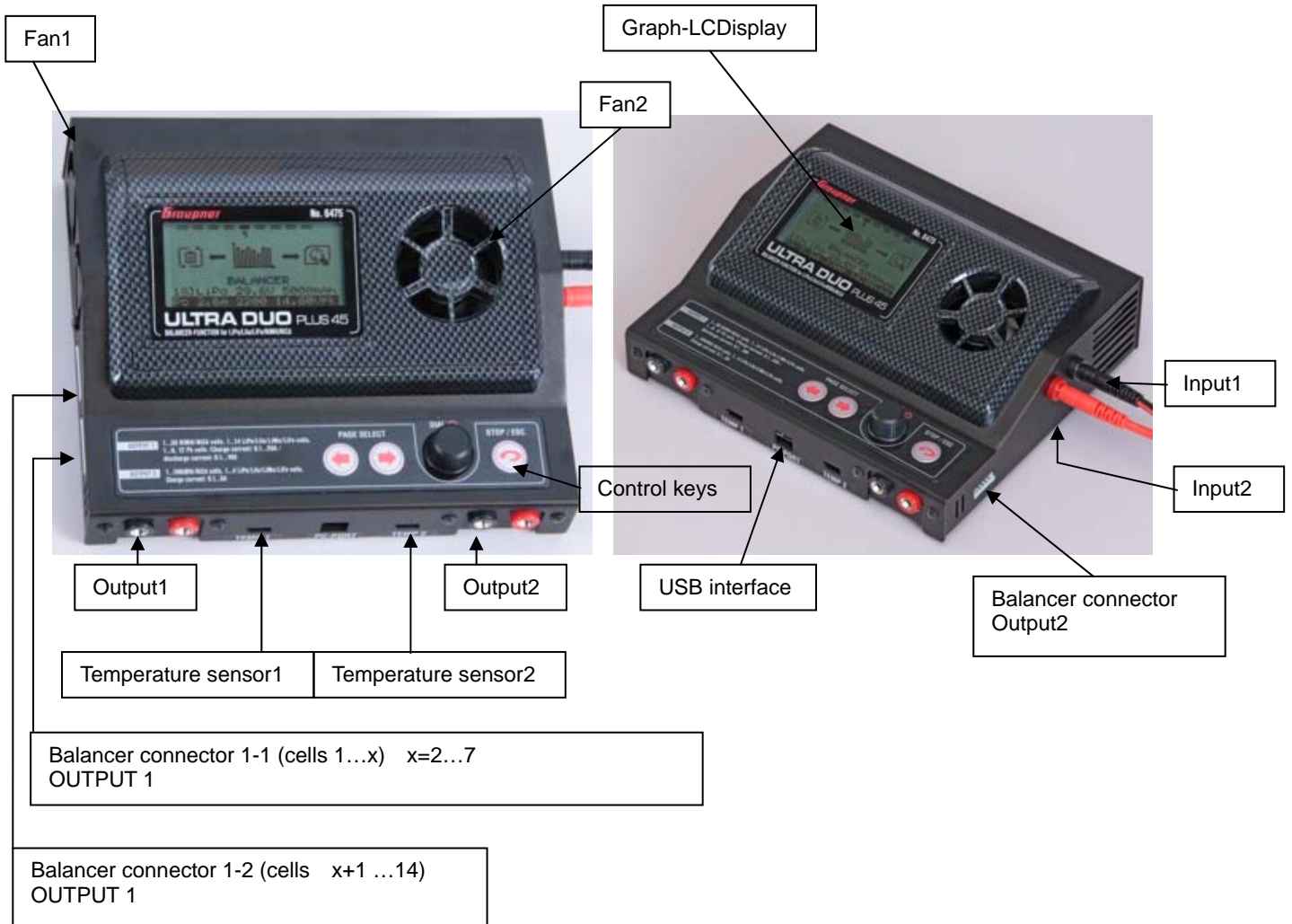

“ The flow chart of ULTRA DUO PLUS 45 Charger ”

0-1. PRODUCT STUCTURE





0-2. MAIN MENU FLOW



Graupner
 ULTRA DUO PLUS 45
 GRAUPNER #6475 V1.0
 USER NAME

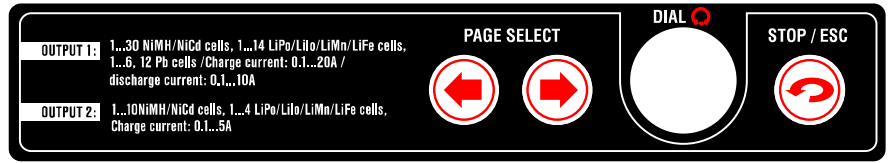

DIAL 2sec. = press the 'DIAL' button for two seconds

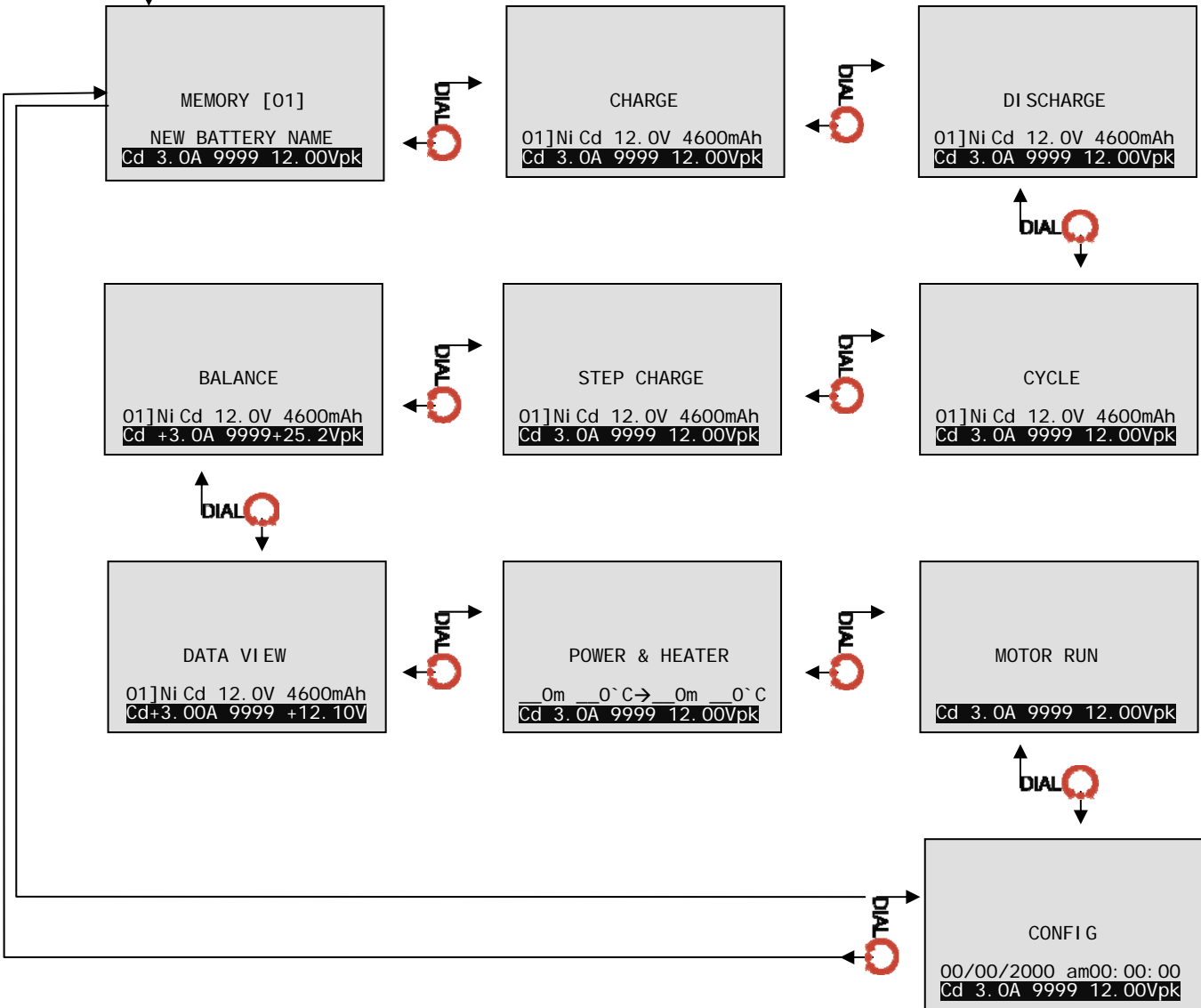



0-3. OUTPUT2 MENU/CHARGE FLOW

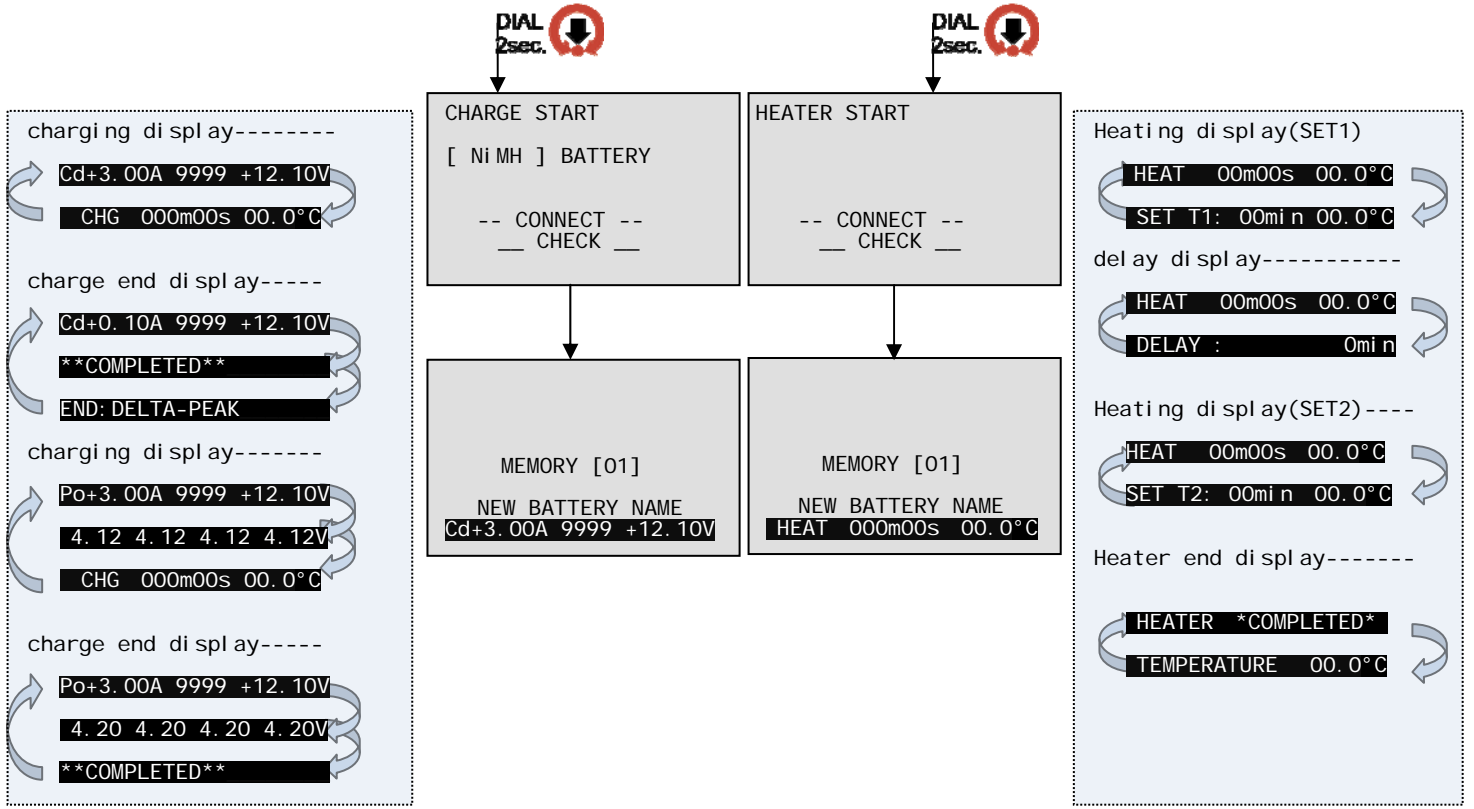
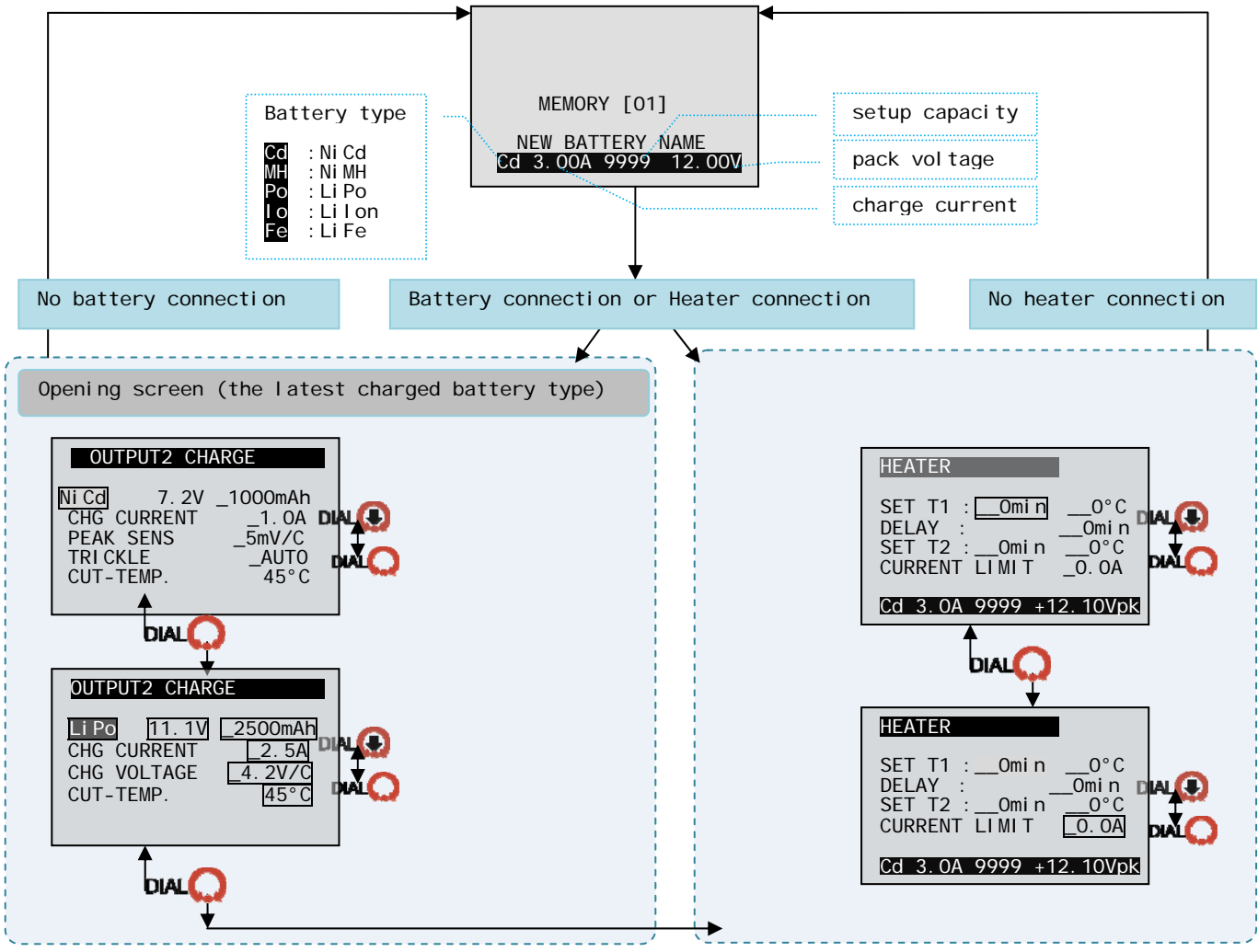



1. MEMORY AND BATTERY SETUP MENU SCREEN

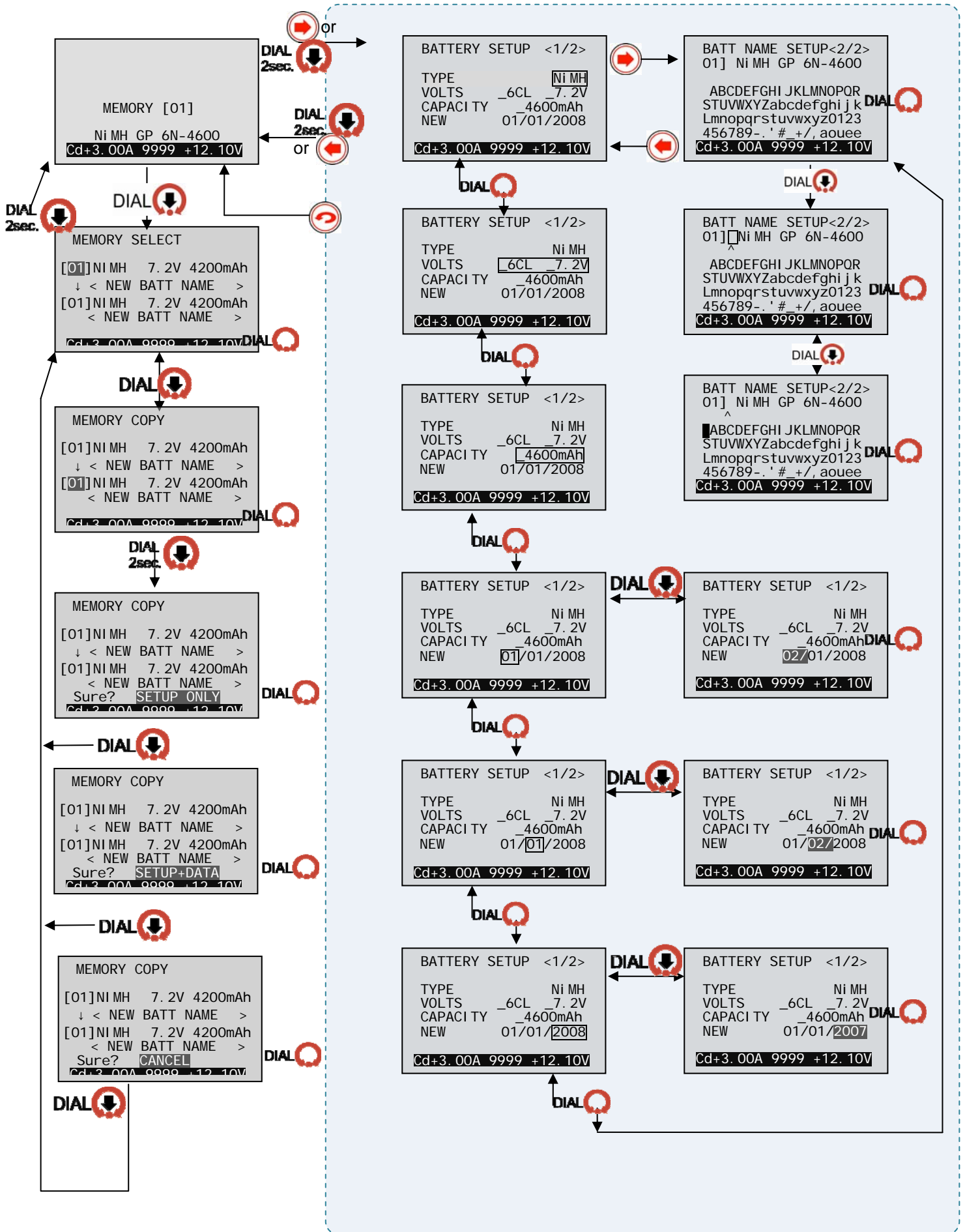



2. CHARGE SETUP MENU FLOW

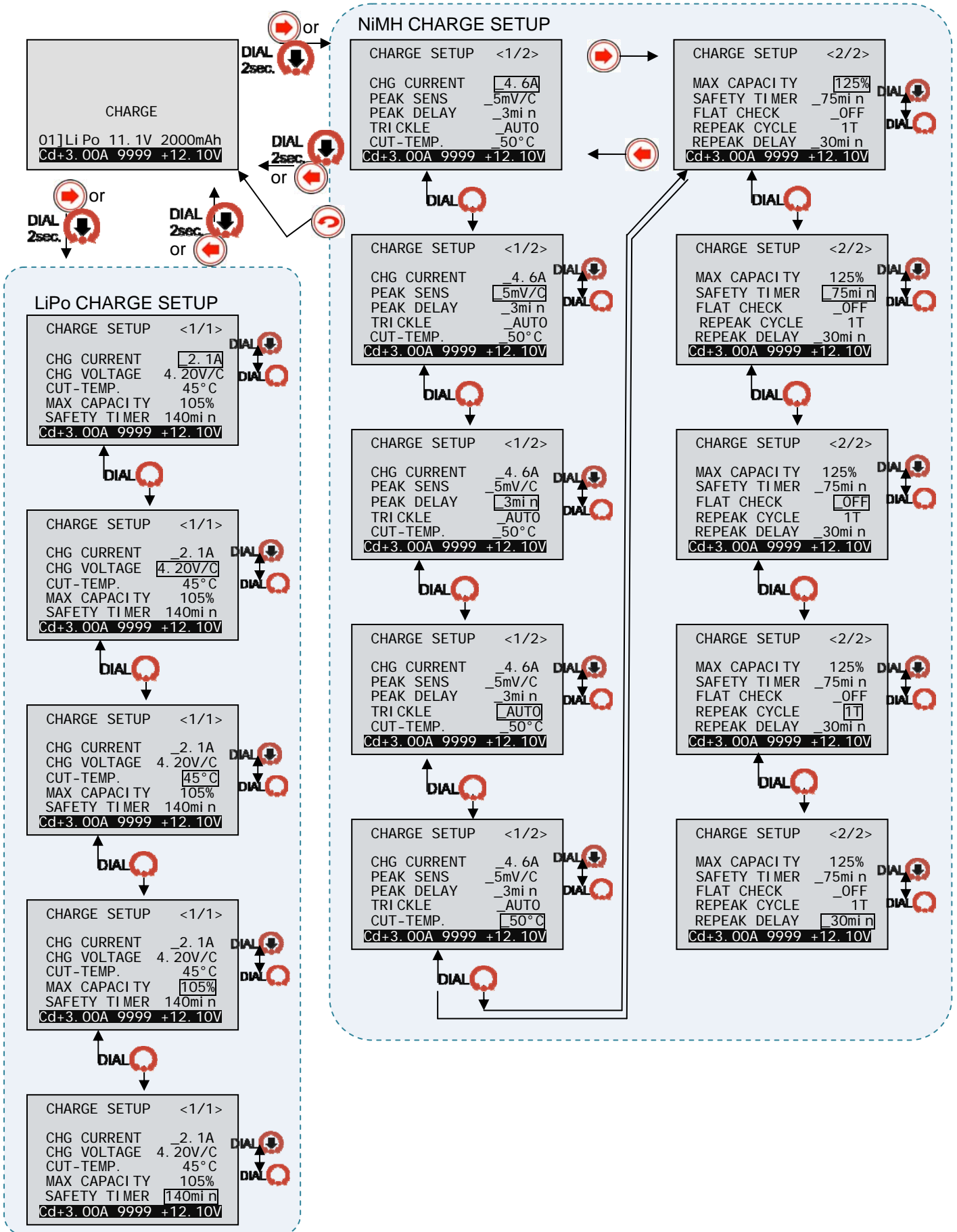



3. DISCHARGE MENU SCREEN

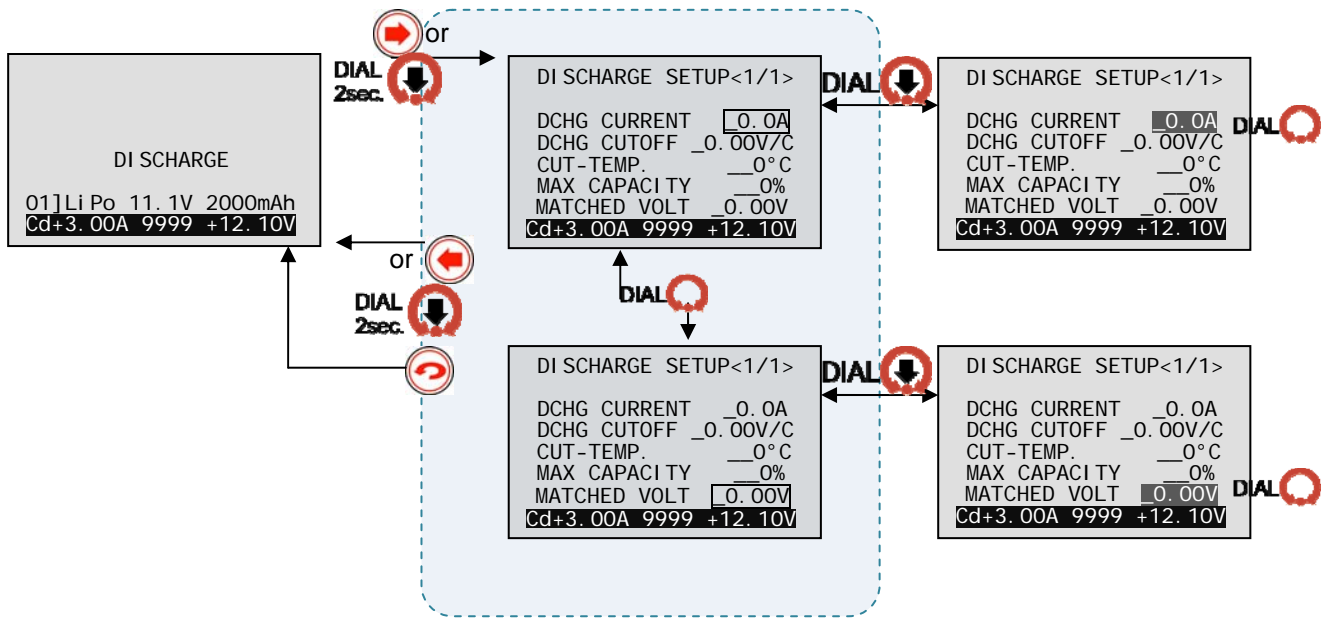



4. CYCLE MENU SCREEN

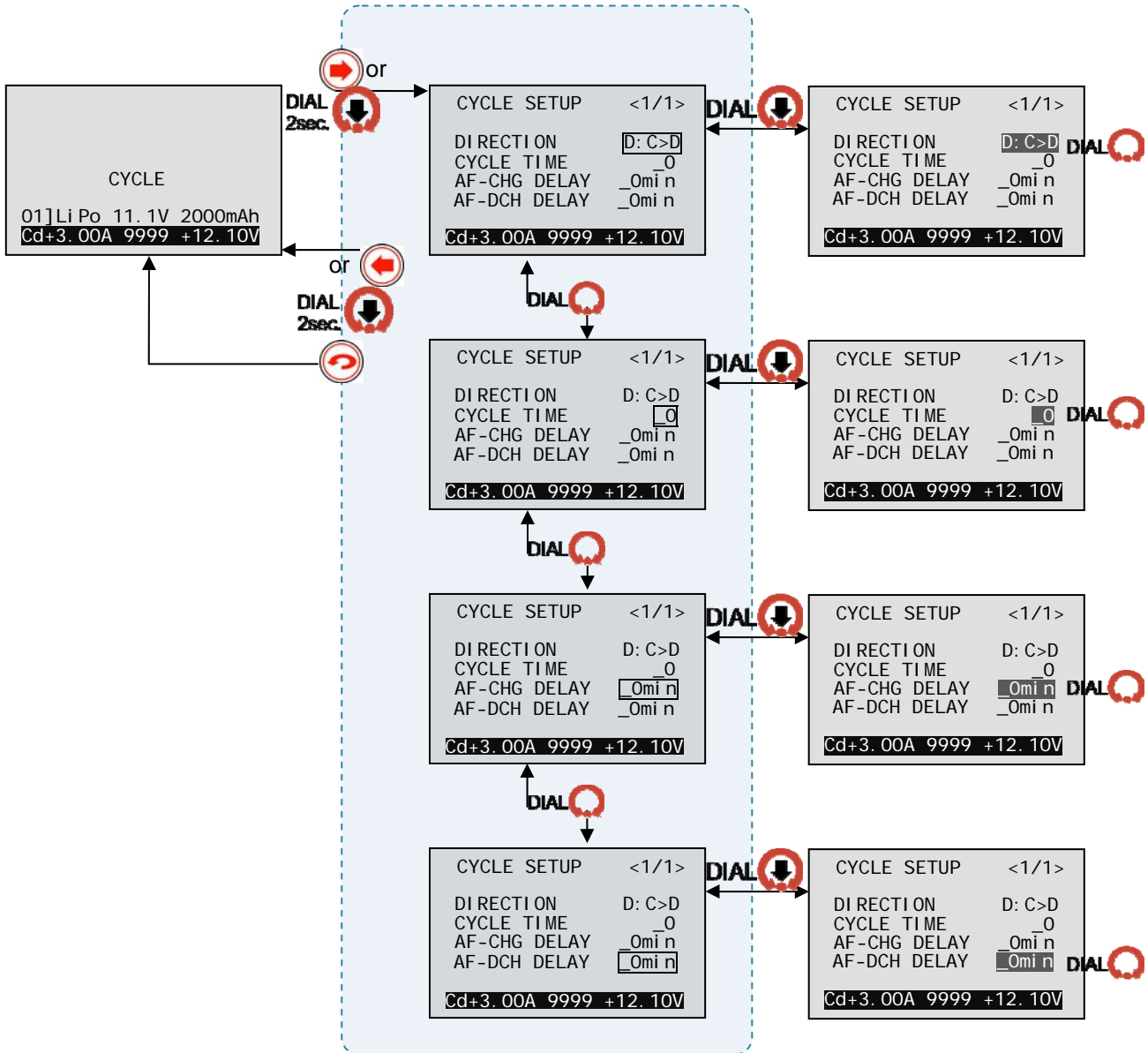



5. STEP CHARGE MENU SCREEN

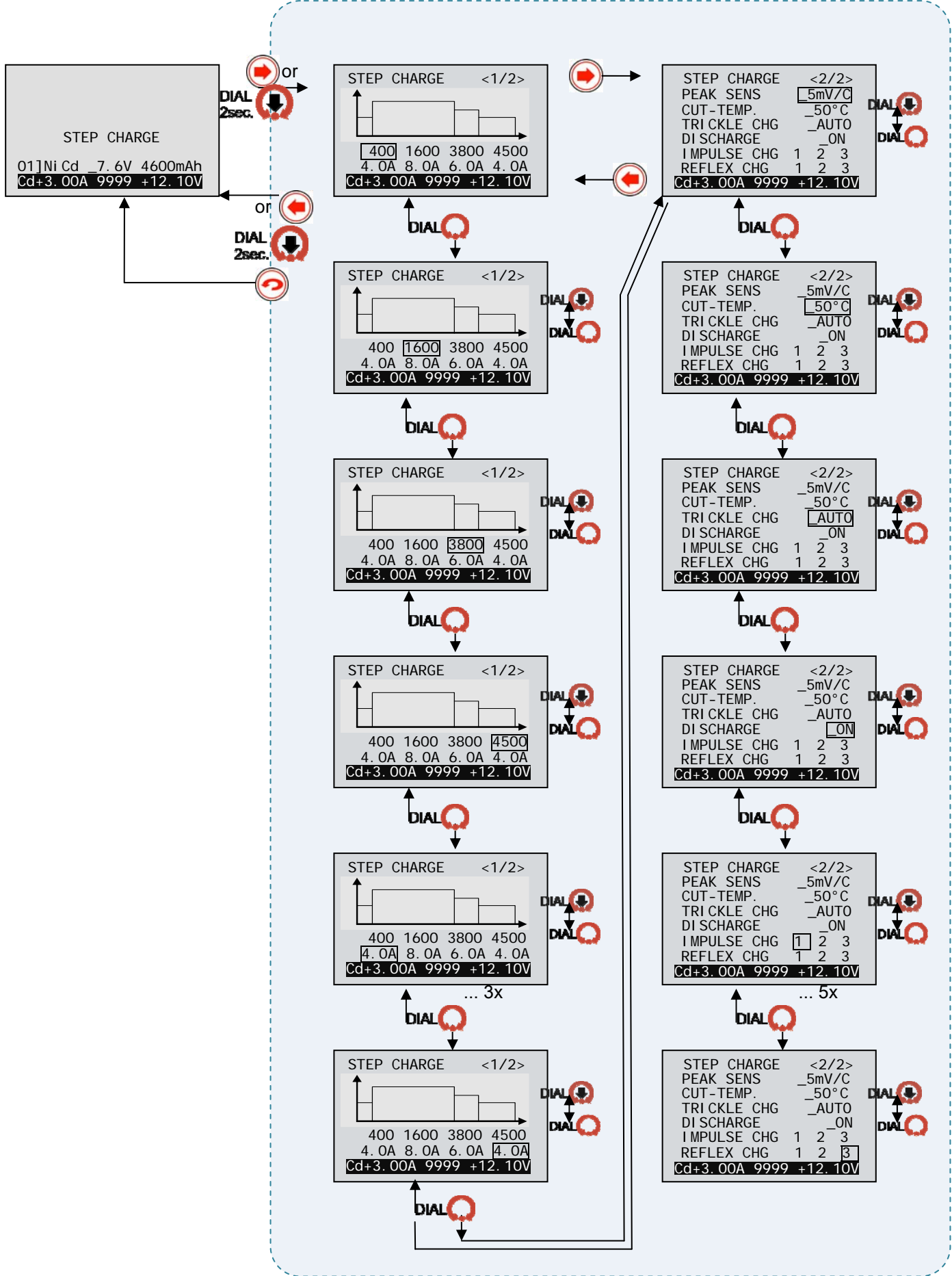



6. BALANCER MENU SCREEN

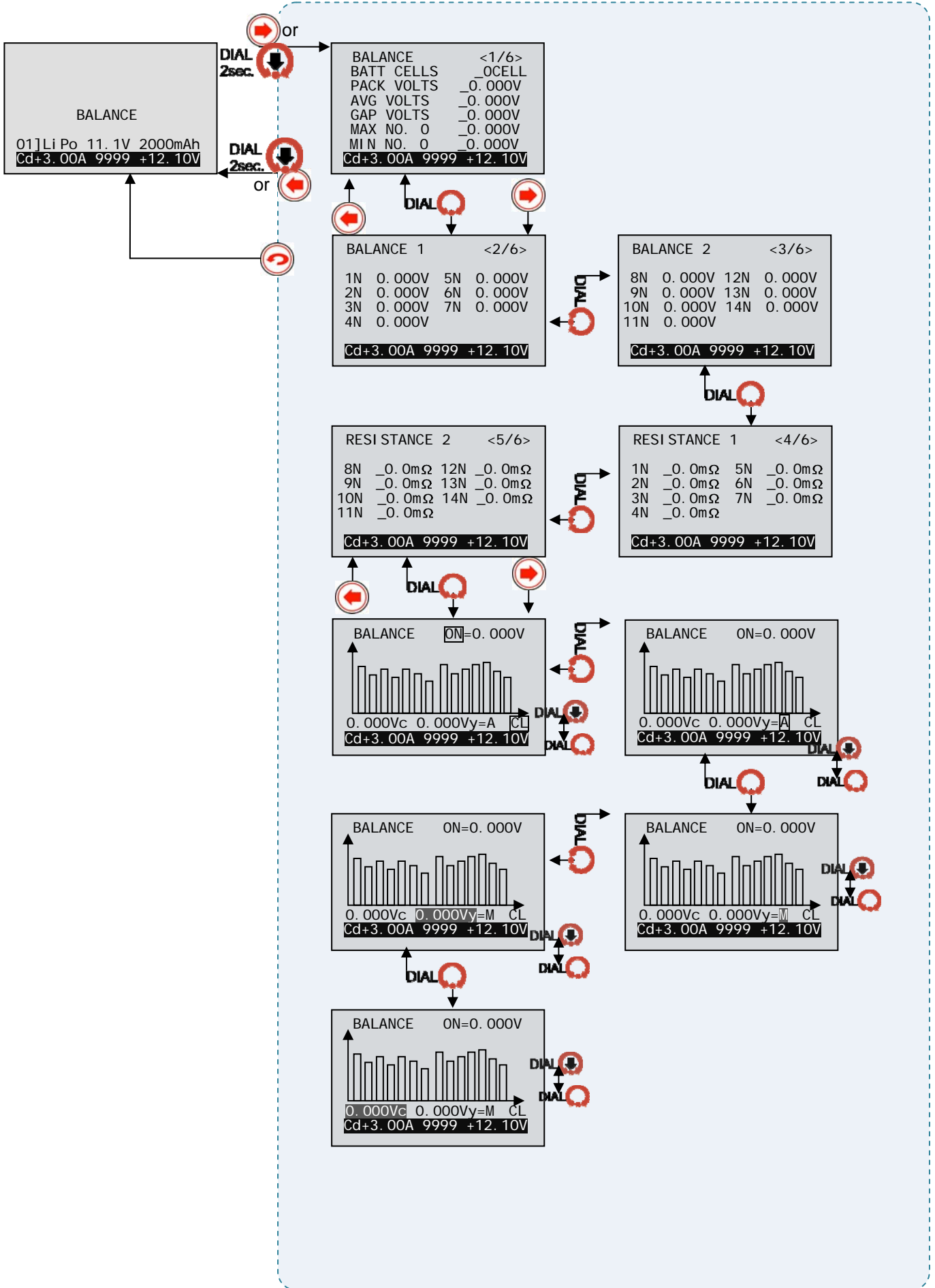



7. DATA VIEW SCREEN

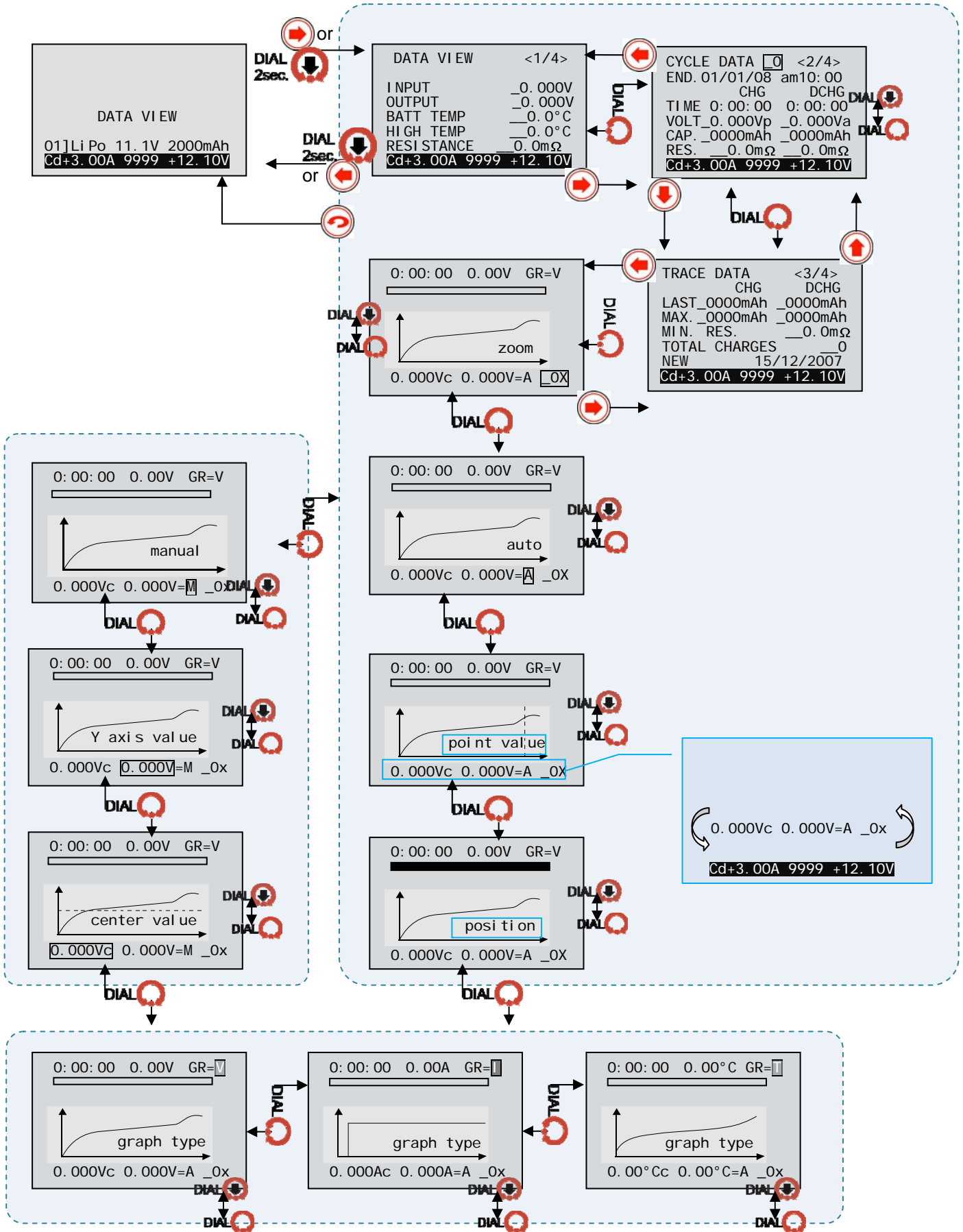



8. TYRE/BATTERY HEATER SCREEN

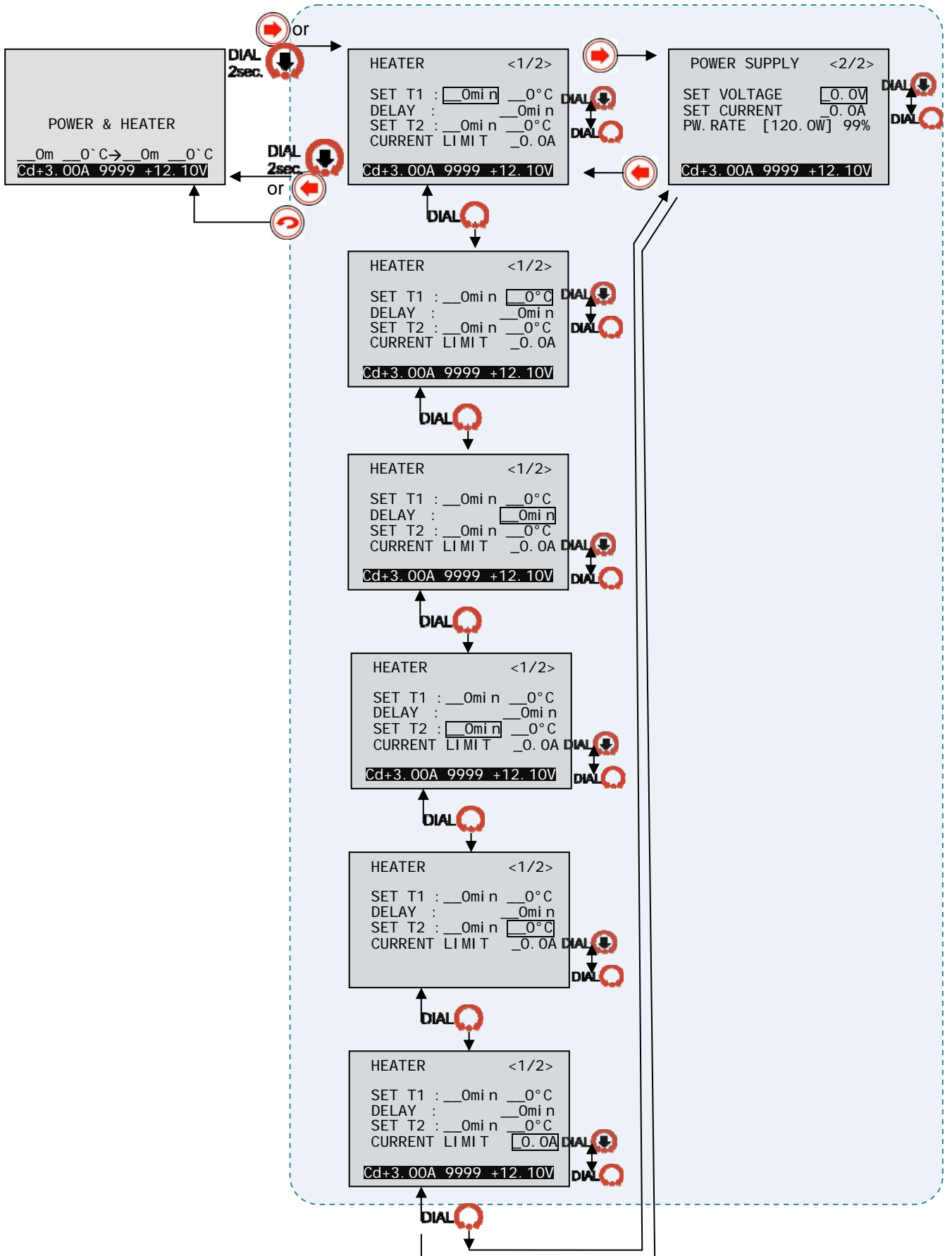



9. MOTOR RUN-IN SCREEN

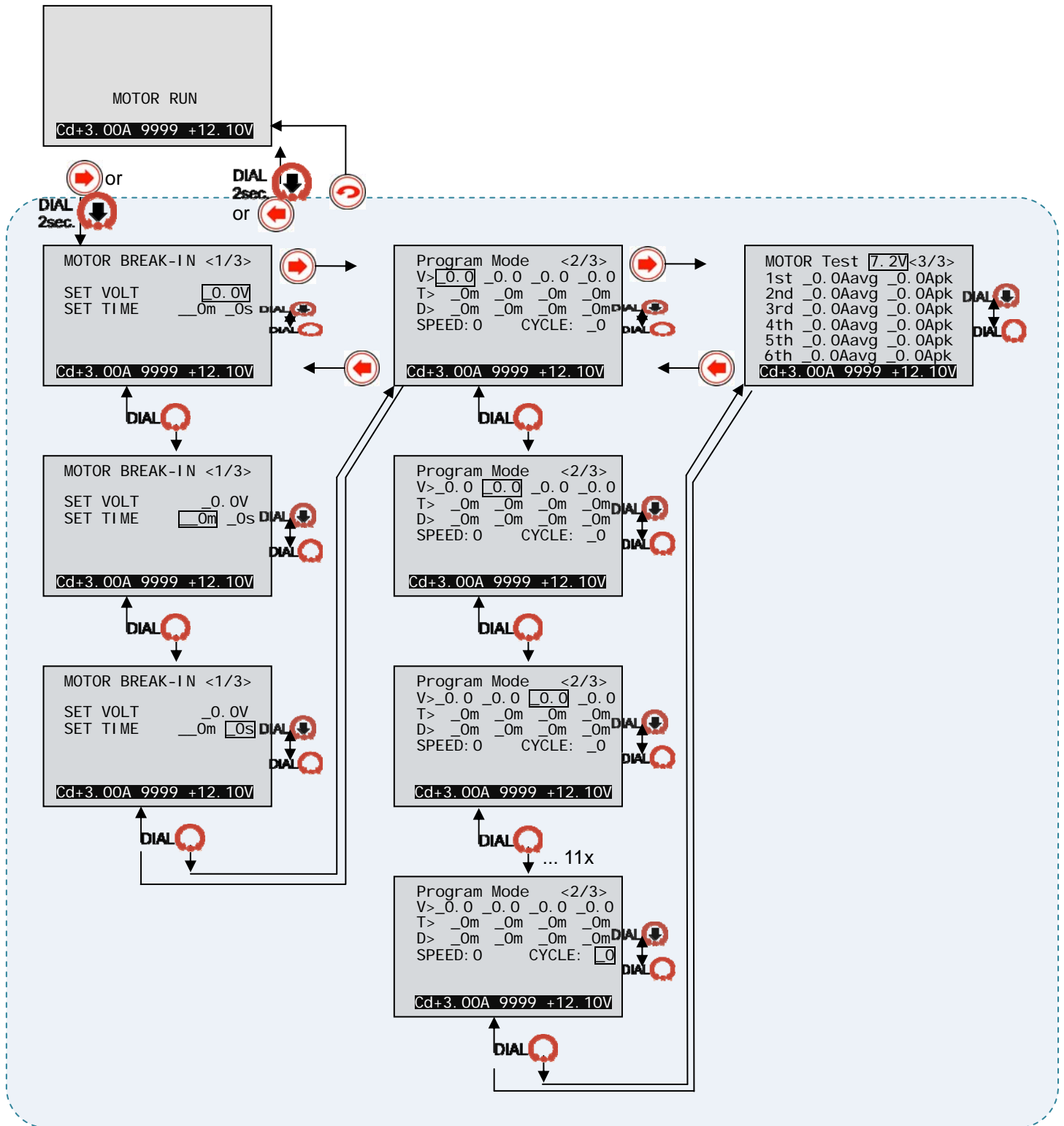



10. CONFIG SETUP SCREEN

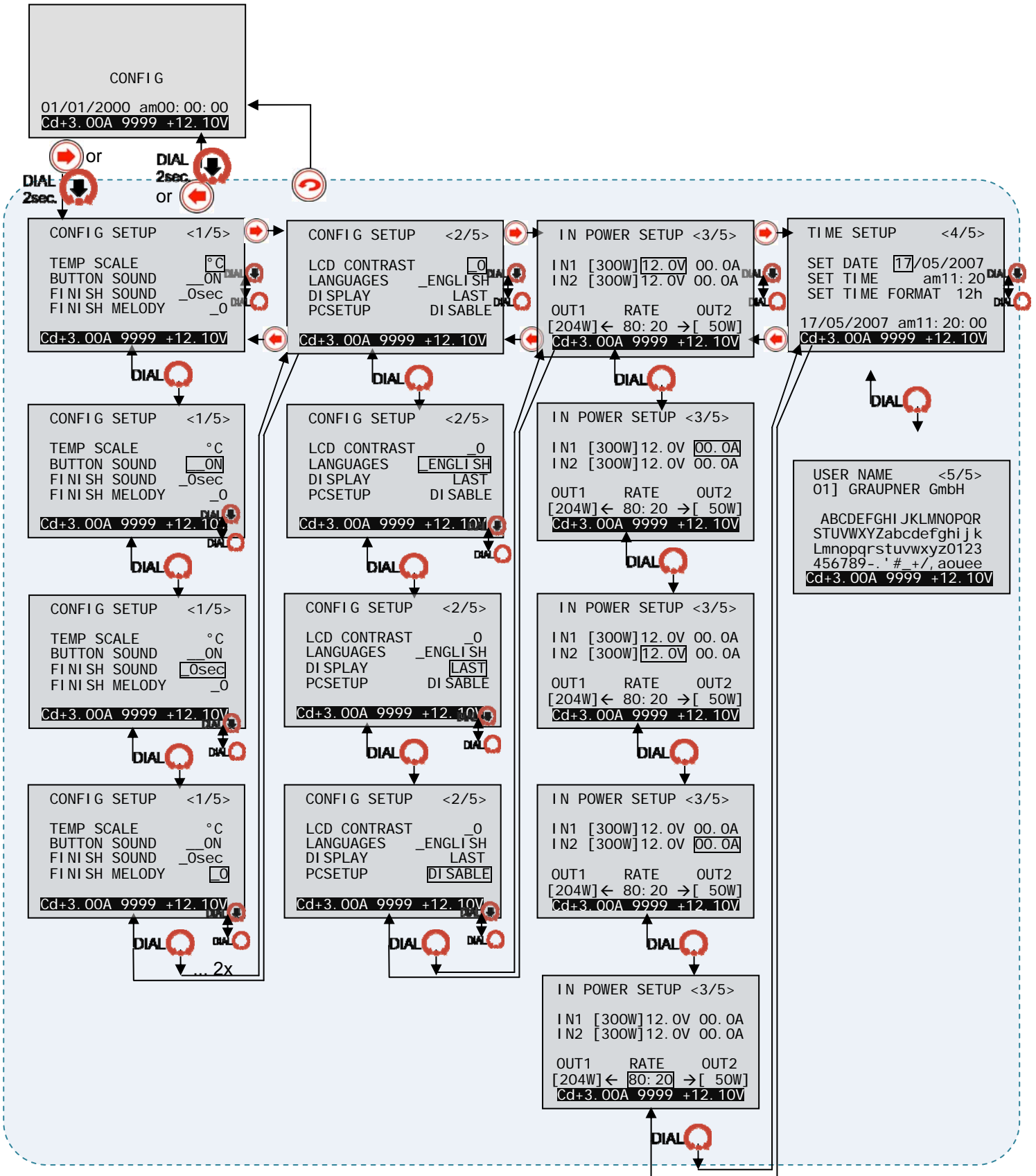



11. START SELECT MENU SCREEN

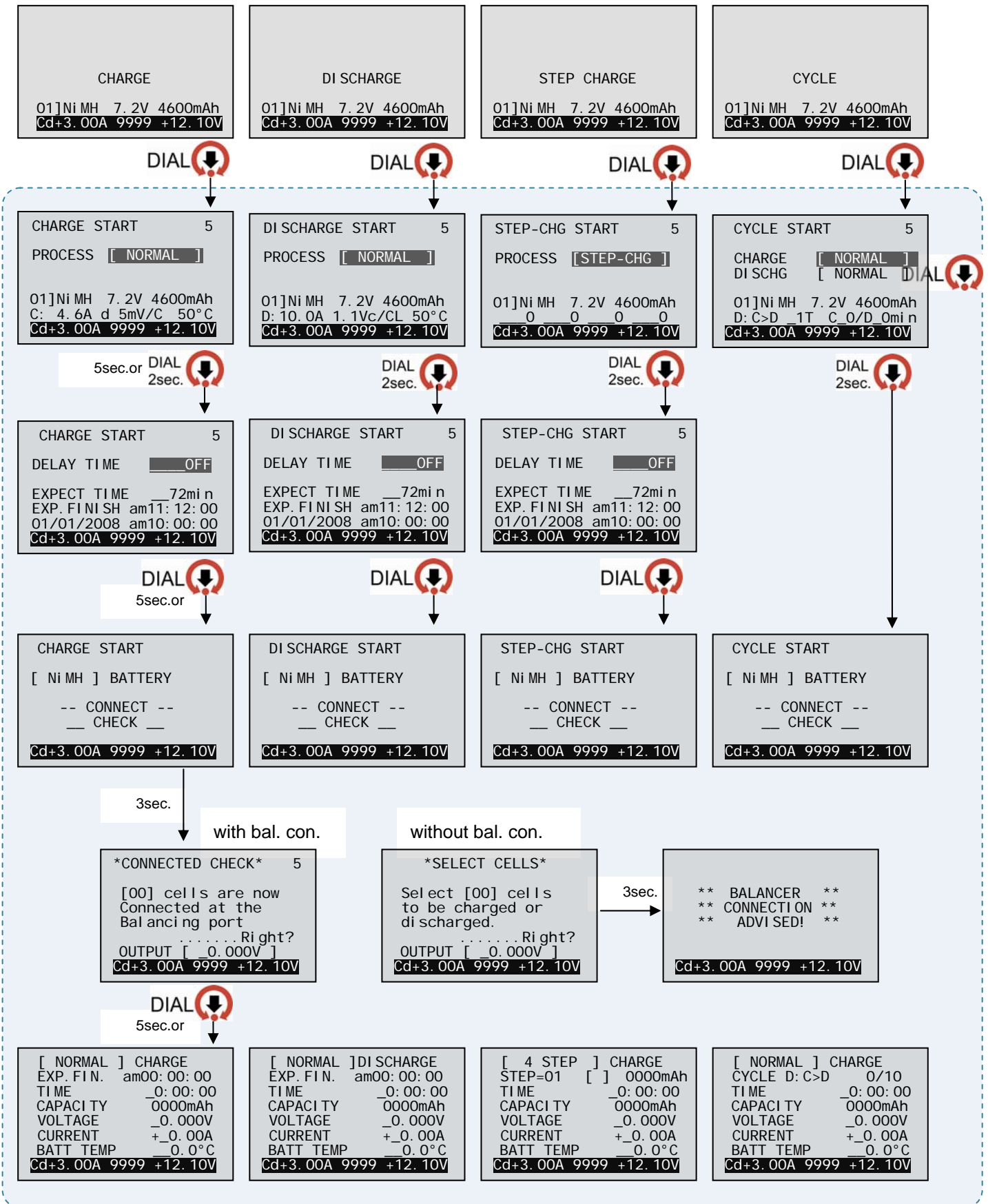

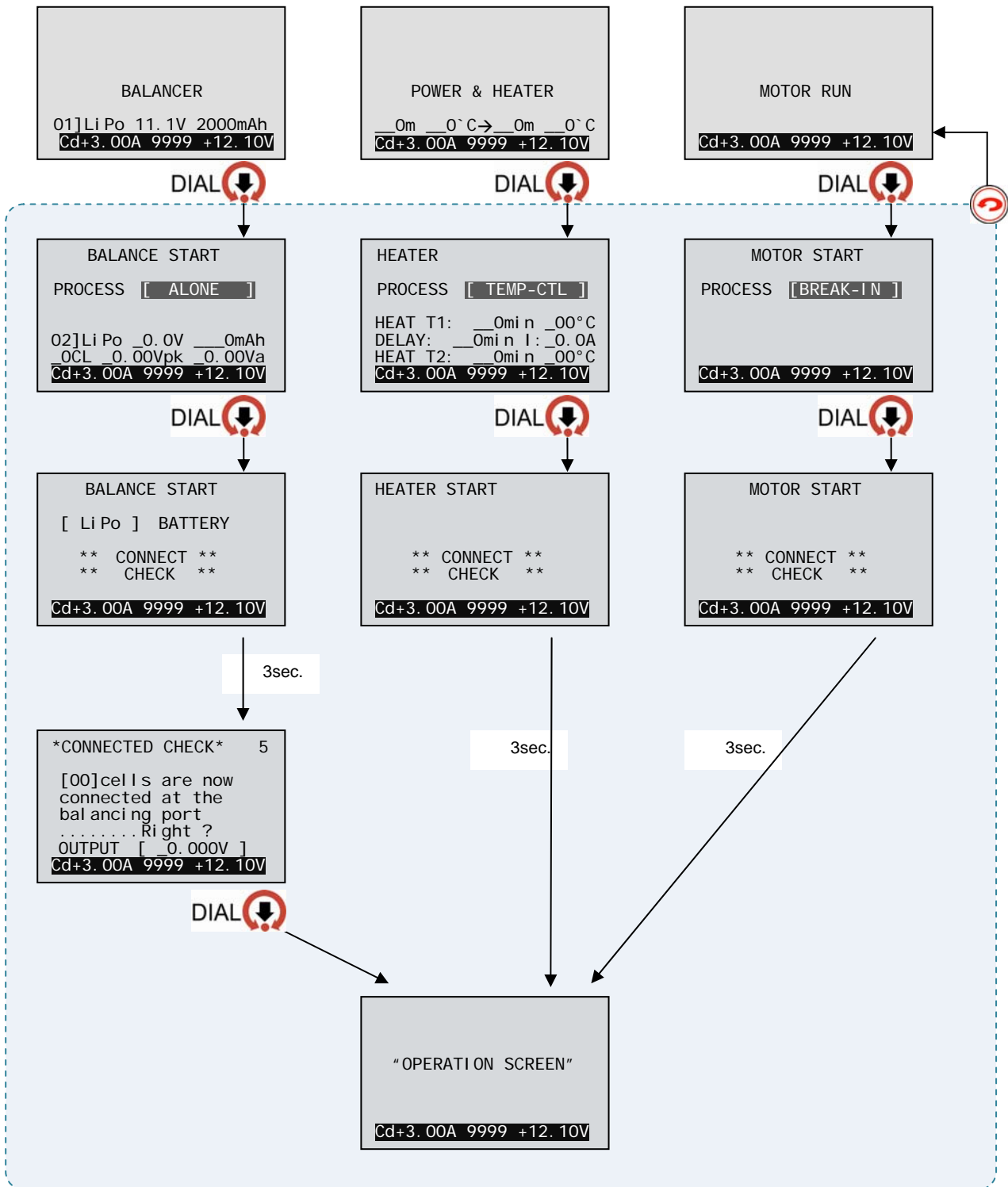



12. BATTERY SELECT MENU SCREEN

With connected balancer
connector in LiPo/LiLo/LiFe
CC/CV- or automatic mode

```

*CONNECTED CHECK*      5
[00] cells are now
Connected at the
Balancing port
.....Right?
OUTPUT [ 0.000V ]
Cd+3.00A 9999 +12.10V

```

Balancer connector not connected in
LiPo/LiLo/LiFe-Mode

```

*SELECT CELLS*
Select [00] cells
to be charged or
discharged.
.....Right?
OUTPUT [ 0.000V ]
Cd+3.00A 9999 +12.10V

```

3 sec.

```

** BALANCER **
** CONNECTION **
** ADVISED! **
Cd+3.00A 9999 +12.10V

```



13. OPERATION MENU SCREEN

< CHARGE, DISCHARGE OPERATION SCREEN >

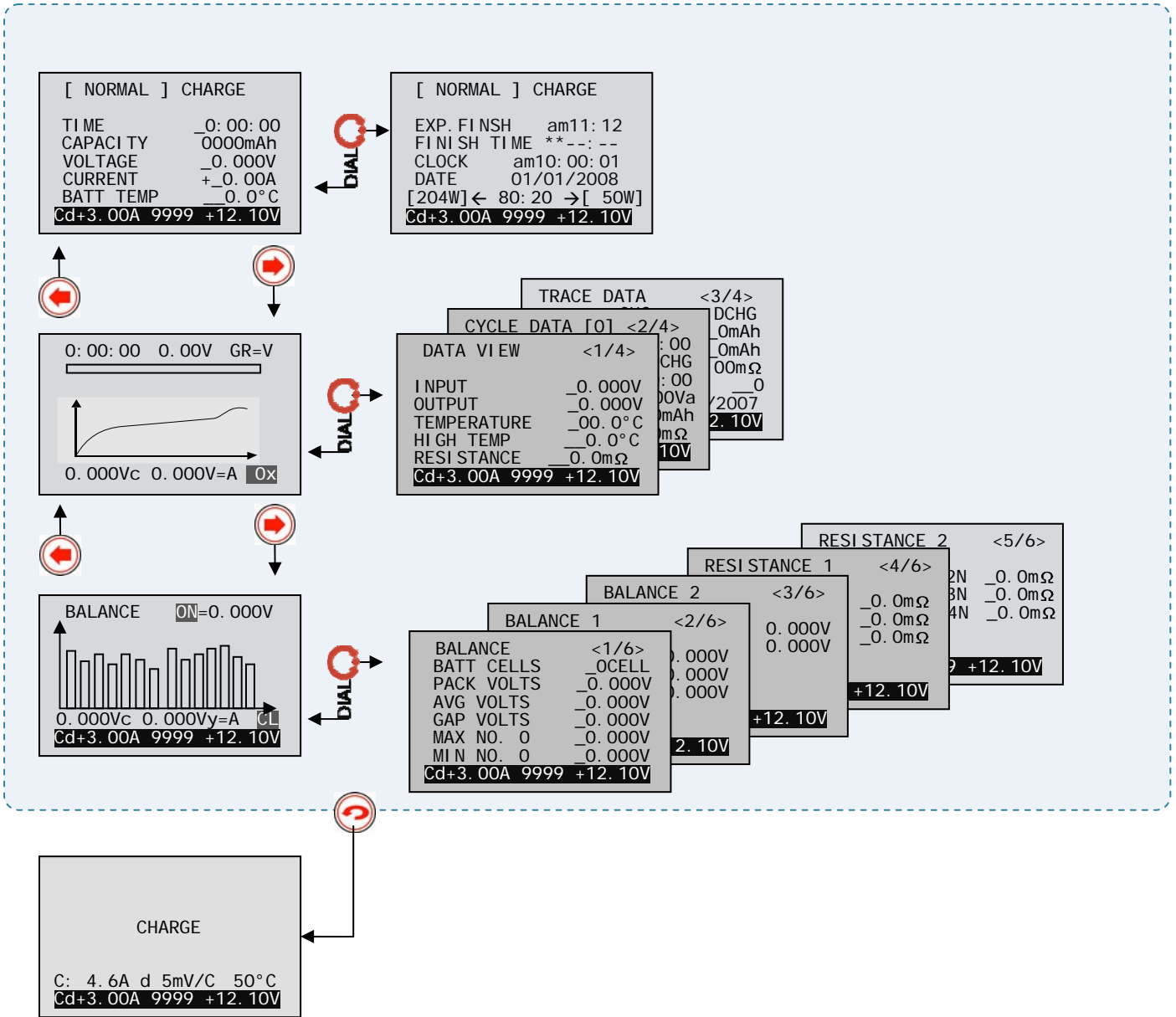

Finish/END Displays:

- "END:DELTA-PEAK "
- "END:ZERO-PEAK "
- "END:CC/CV "
- "END:CUTOFF-VOLT"
- "END:TEMPERATURE"
- "END:CAPACITY "
- "END:FLAT CHECK "
- "END:TIMER "
- "CHK:MATCHED "

```

[ NORMAL ] CHARGE
END: DELTA-PEAK
TIME      _0: 00: 00
CAPACITY  _0000mAh
VOLTAGE   _0. 000V
CURRENT   +_0. 00A
BATT TEMP _0. 0°C
Cd+3.00A 9999 +12.10V
  
```



< CYCLE OPERATION SCREEN >

D:C>D

C>D

D>C

```

[ NORMAL ] DISCHARGE
CYCLE D:C>D    0/10
TIME           _0: 00: 00
CAPACITY      0000mAh
VOLTAGE       _0. 000V
CURRENT       +_0. 00A
BATT TEMP     _0. 0°C
Cd+3.00A 9999 +12.10V
  
```

```

[ CYCLE ] DELAY
LEFT TIME     _0m 00s
CYCLE _C>D   _0/00
OUTPUT        _0. 000V
BATT TEMP     _0. 0°C
Cd+3.00A 9999 +12.10V
  
```

```

[ NORMAL ] CHARGE
CYCLE C>D     1/10
TIME          _0: 00: 00
CAPACITY      0000mAh
VOLTAGE       _0. 000V
CURRENT       +_0. 00A
BATT TEMP     _0. 0°C
Cd+3.00A 9999 +12.10V
  
```

```

[ CYCLE ] DELAY
LEFT TIME     _0m 00s
CYCLE _C>D   _0/00
OUTPUT        _0. 000V
BATT TEMP     _0. 0°C
Cd+3.00A 9999 +12.10V
  
```

```

[ NORMAL ] DISCHARGE
CYCLE C>D     1/10
TIME          _0: 00: 00
CAPACITY      0000mAh
VOLTAGE       _0. 000V
CURRENT       +_0. 00A
BATT TEMP     _0. 0°C
Cd+3.00A 9999 +12.10V
  
```

```

[ NORMAL ] DISCHARGE
END: CUTOFF-VOLT
TIME          _0: 00: 00
CAPACITY      0000mAh
VOLTAGE       _0. 000V
CURRENT       +_0. 00A
BATT TEMP     _0. 0°C
Cd+3.00A 9999 +12.10V
  
```

```

[ NORMAL ] CHARGE
CYCLE C>D     1/10
TIME          _0: 00: 00
CAPACITY      0000mAh
VOLTAGE       _0. 000V
CURRENT       +_0. 00A
BATT TEMP     _0. 0°C
Cd+3.00A 9999 +12.10V
  
```

```

[ CYCLE ] DELAY
LEFT TIME     _0m 00s
CYCLE _C>D   _0/00
OUTPUT        _0. 000V
BATT TEMP     _0. 0°C
Cd+3.00A 9999 +12.10V
  
```

```

[ NORMAL ] DISCHARGE
CYCLE C>D     1/10
TIME          _0: 00: 00
CAPACITY      0000mAh
VOLTAGE       _0. 000V
CURRENT       +_0. 00A
BATT TEMP     _0. 0°C
Cd+3.00A 9999 +12.10V
  
```

```

[ CYCLE ] DELAY
LEFT TIME     _0m 00s
CYCLE _C>D   _0/00
OUTPUT        _0. 000V
BATT TEMP     _0. 0°C
Cd+3.00A 9999 +12.10V
  
```

```

[ NORMAL ] DISCHARGE
END: CUTOFF-VOLT
TIME          _0: 00: 00
CAPACITY      0000mAh
VOLTAGE       _0. 000V
CURRENT       +_0. 00A
BATT TEMP     _0. 0°C
Cd+3.00A 9999 +12.10V
  
```

```

[ NORMAL ] DISCHARGE
CYCLE D>C     1/10
TIME          _0: 00: 00
CAPACITY      0000mAh
VOLTAGE       _0. 000V
CURRENT       +_0. 00A
BATT TEMP     _0. 0°C
Cd+3.00A 9999 +12.10V
  
```

```

[ CYCLE ] DELAY
LEFT TIME     _0m 00s
CYCLE _D>C   _0/00
OUTPUT        _0. 000V
BATT TEMP     _0. 0°C
Cd+3.00A 9999 +12.10V
  
```

```

[ NORMAL ] CHARGE
CYCLE D>C     1/10
TIME          _0: 00: 00
CAPACITY      0000mAh
VOLTAGE       _0. 000V
CURRENT       +_0. 00A
BATT TEMP     _0. 0°C
Cd+3.00A 9999 +12.10V
  
```

```

[ CYCLE ] DELAY
LEFT TIME     _0m 00s
CYCLE _D>C   _0/00
OUTPUT        _0. 000V
BATT TEMP     _0. 0°C
Cd+3.00A 9999 +12.10V
  
```

```

[ NORMAL ] CHARGE
END: DELTA-PEAK
TIME          _0: 00: 00
CAPACITY      0000mAh
VOLTAGE       _0. 000V
CURRENT       +_0. 00A
BATT TEMP     _0. 0°C
Cd+3.00A 9999 +12.10V
  
```



```

CYCLE
01]LiPo 11.1V 2000mAh
Cd+3.00A 9999 +12.10V
  
```



< STEP-CHARGE, REPEAK OPERATION SCREEN >

Step-charge:

Repeak charge:

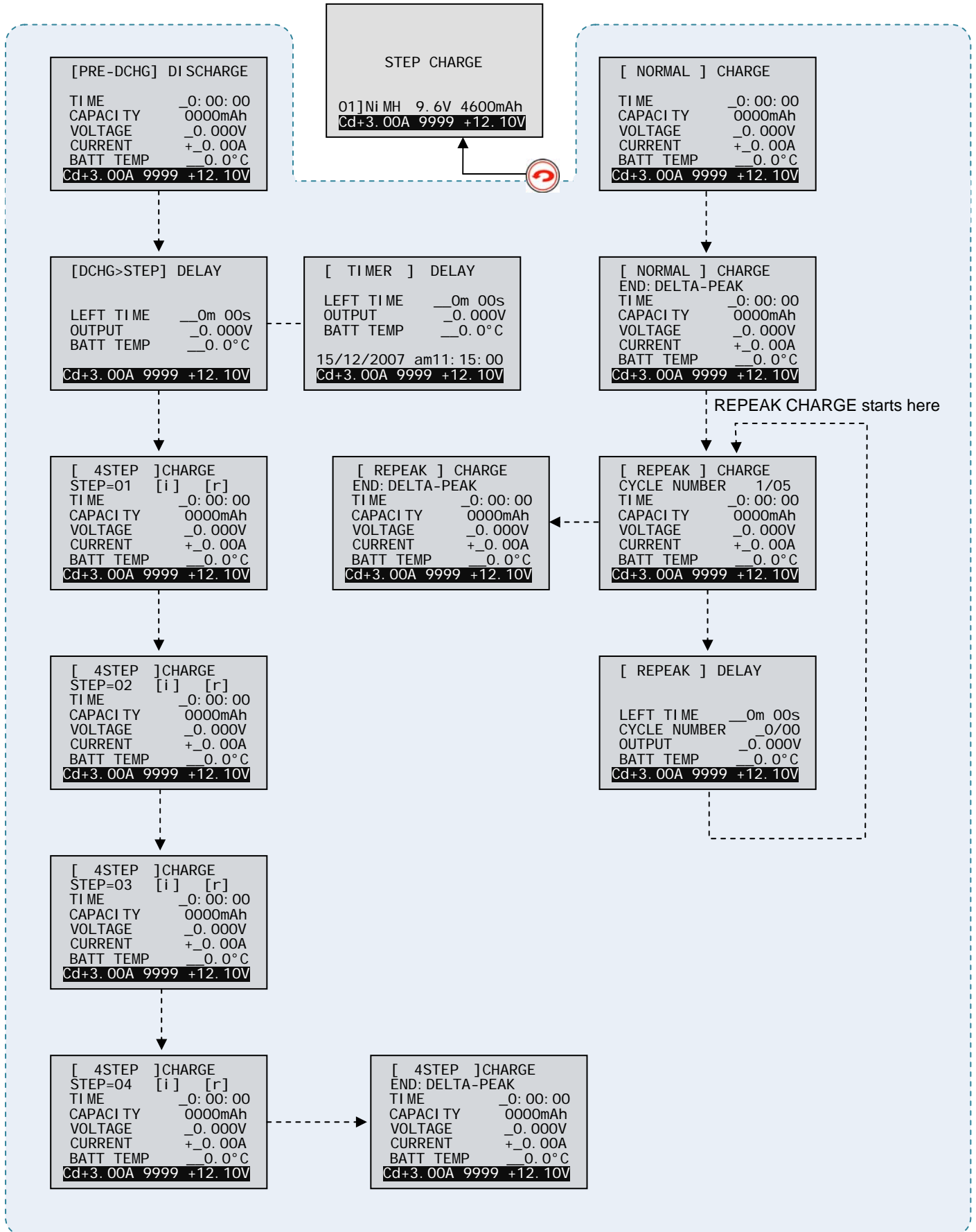



< BALANCE ALONE OPERATION SCREEN >

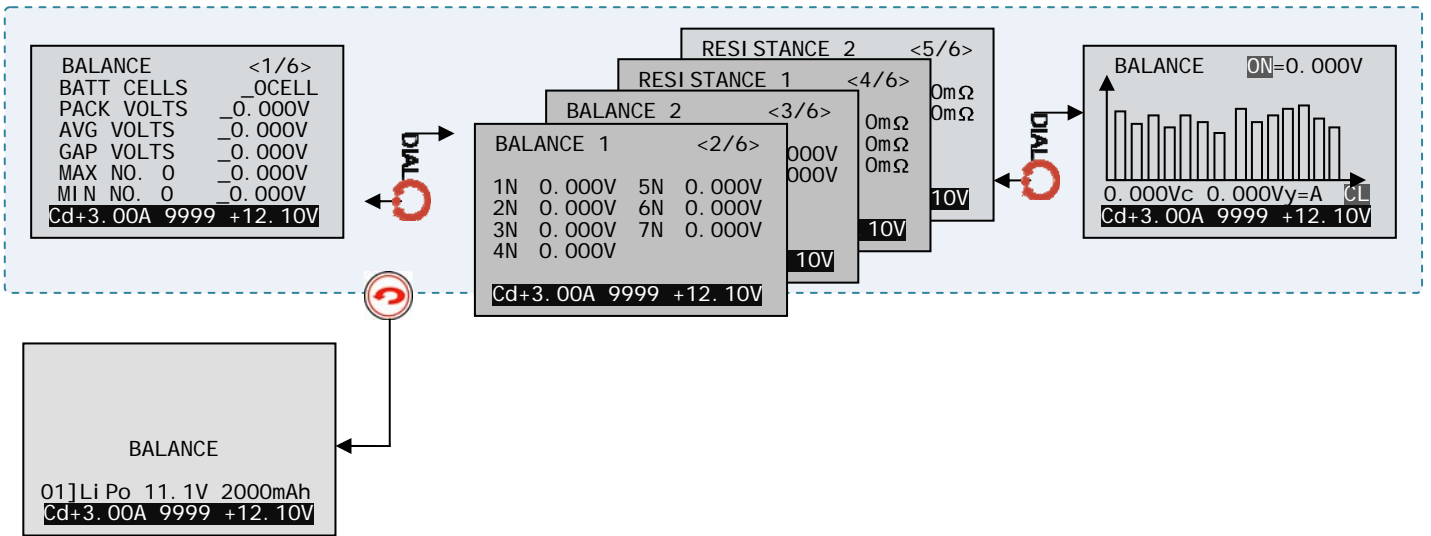

< TYRE/BATTERY HEATER OPERATION SCREEN >

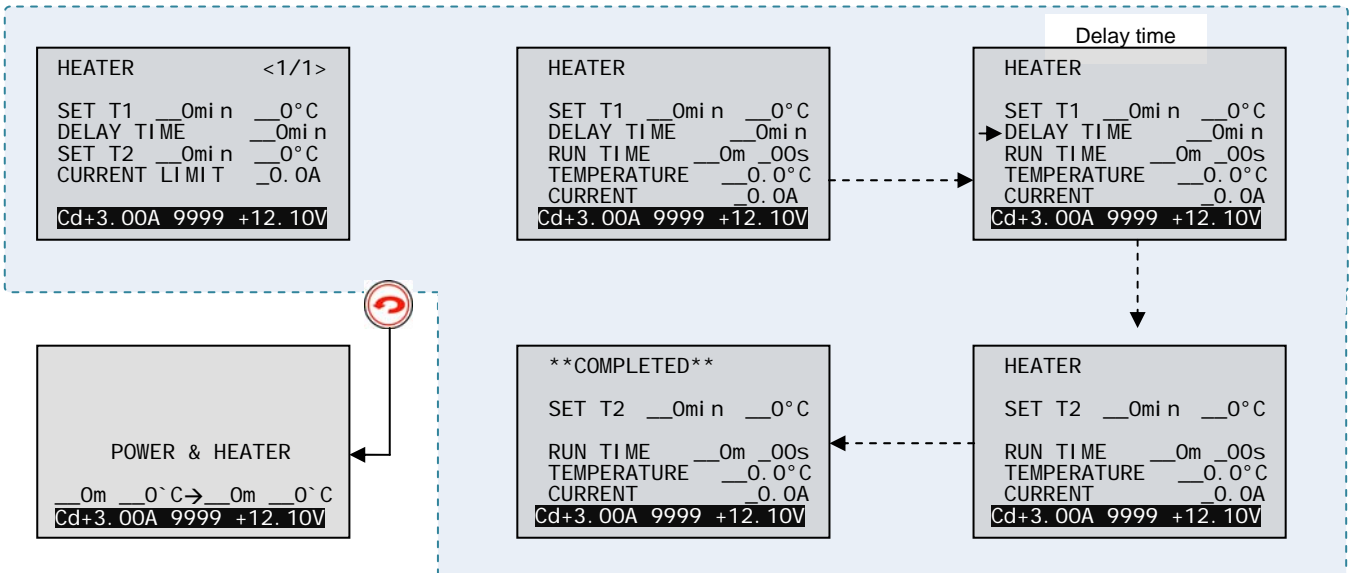

< POWER SUPPLY OPERATION SCREEN >

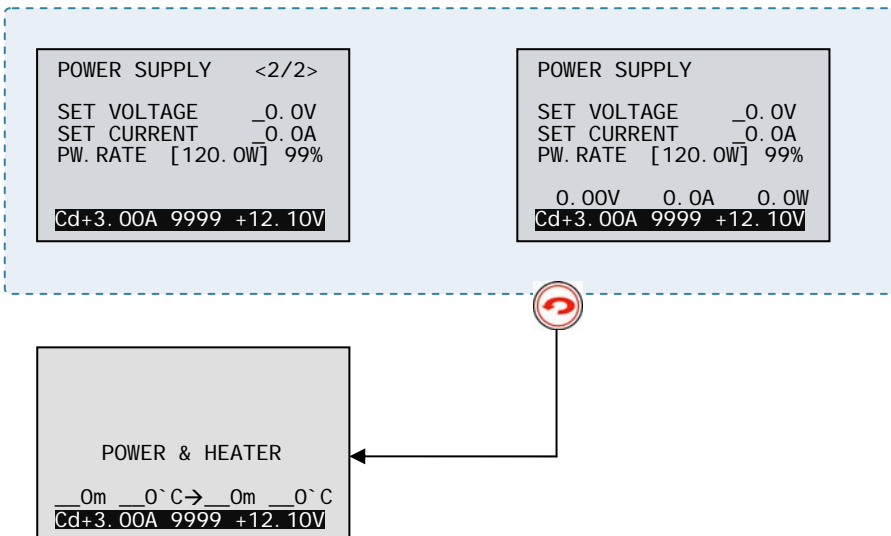



< MOTOR OPERATION SCREEN >

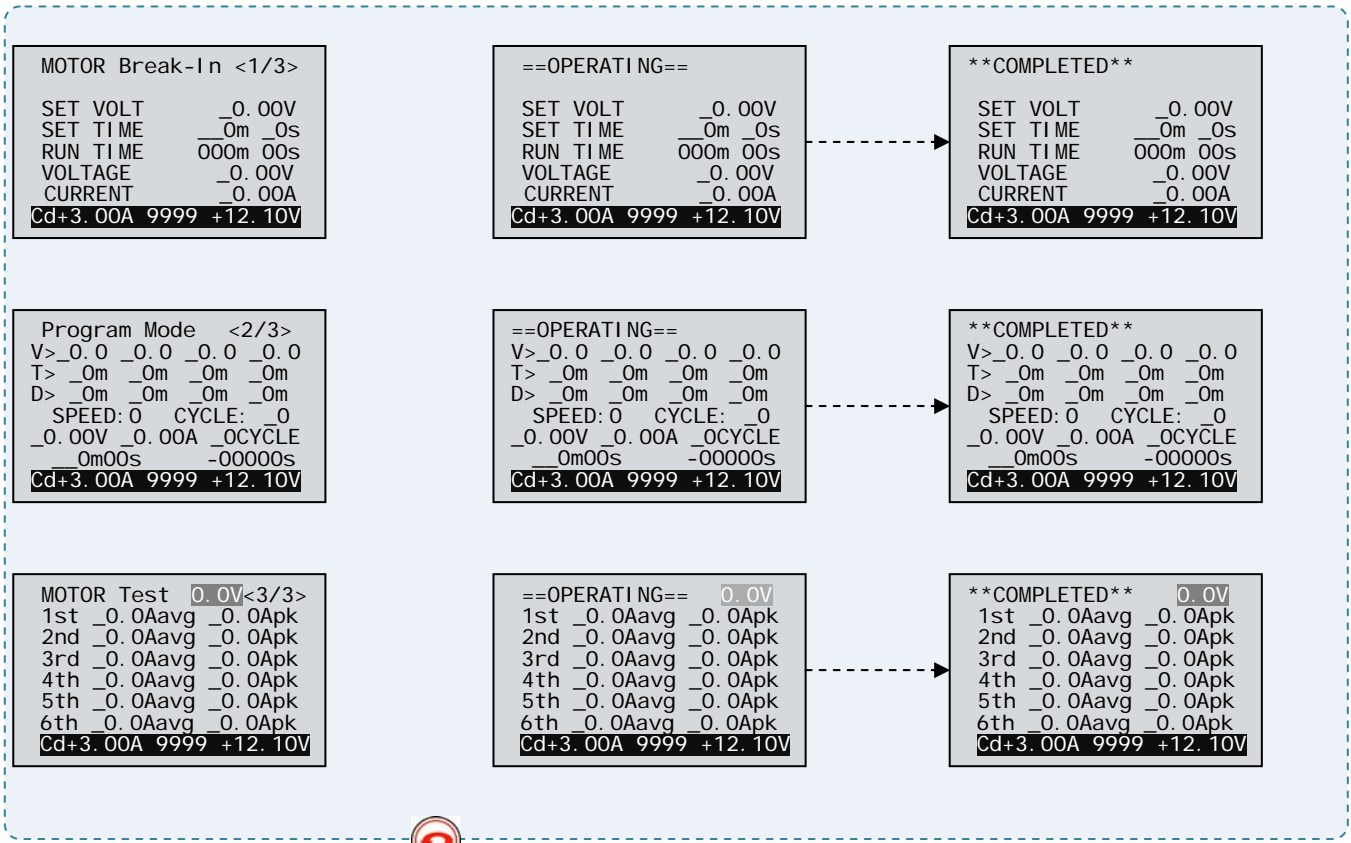

MOTOR RUN
Cd+3.00A 9999 +12.10V



14. ERROR MESSAGE SCREEN

OUTPUT 1 error message

OUTPUT 2 error message

[NO BATTERY]
 * A battery is not connected to the output
 * Please connect the battery to the output then restart
 [NO BATTERY]

[REVERSE POLARITY]
 * A battery is connected to the output in reverse !
 * Please correctly connect the battery to the output.
 [REVERSE POLARITY]

[INPUT VOLTAGE]
 * The present input voltage is _0.00V.
 * Please check the input voltage.
 * The input voltage must be 11-15V.
 [INPUT VOLTAGE]

[SHORT-CIRCUITED]
 * Output short-circuited.
 * Please check the output.
 [SHORT-CIRCUITED]

[LOW OUTPUT VOLTAGE]
 * Output voltage is lower than the selected cells or voltages
 [LOW OUTPUT VOLTAGE]

[OPEN CIRCUIT]
 * A battery is disconnected during an operation.
 * Please reconnect the battery and restart!
 [OPEN CIRCUIT]

[TEMPERATURE SENSOR]
 * A temperature sensor is connected in reverse or is defective.
 [TEMPERATURE SENSOR]

[BAT. TEMP TOO LOW]
 * Battery temp is too low to be operated!
 OUTPUT _0.000V
 BATT TEMP _0.0°F
 [BAT. TEMP TOO LOW]

[HIGH OUTPUT VOLTAGE]
 * Output voltage is higher than the selected cells or voltages
 [HIGH OUTPUT VOLTAGE]

[INTERNAL TEMP]
 * Internal temp is too hot !
 * Contact Hobby Services if this message appears often.
 [INTERNAL TEMP]

[DATA COMMUNICATION]
 * Something is wrong with the internal circuit.
 * Contact Hobby Services
 [DATA COMMUNICATION]

[BAT. TEMP TOO HIGH]
 * Battery temp is too high to be operated!
 OUTPUT _0.000V
 BATT TEMP _0.0°F
 [BAT. TEMP TOO HIGH]

[BAL. VOLTAGE LOW]
 * Balancer cells voltage is too low !!
 low cell is [00]
 [BAL. VOLTAGE LOW]

[CALIBRATION DATA]
 * Either calibration data or internal circuit might have been damaged.
 [CALIBRATION DATA]

[BAL. VOLTAGE HIGH]
 * Balancer cells voltage is too high !!
 over cell is [00]
 [BAL. VOLTAGE HIGH]

[NO TEMP. SENSOR]
 * A temp-sensor is not connected to the port
 * Please connect the temp-sensor to the port then restart !
 [NO TEMP. SENSOR]

[MOTOR OVER CURRENT]
 * Please reconnect the motor and restart!
 Cd+3.00A 9999 +12.10V

[]

[CONNECTION]
 * selected cells and cells connected to the balancing port are different !
 * Please recheck and restart !
 [CONNECTION]

[MOTOR FUNCTION]
 * Can not start the motor function, because other Output is used !
 Cd+3.00A 9999 +12.10V